

# EBIOS FIRE

by SPARTHERM®



## DECO FIRE

Fire for any ambiance.



Exceptional interior design with a natural-style Deco Fire at its centre

## INDEX

INTRODUCTION	6
BENEFITS	7
LINE	10
LINE FACTS	14
LINE+	16
LINE+ FACTS	18
BOX	20
BOX FACTS	24
CONVENIENCE AND SAFETY	26

**NOTE:**

Colours may differ slightly from actual colours, due to the printing process. Technical data and colours subject to change. Errors and omissions excepted.



# SPECTACULAR FIRE DESIGN

– SAFE, CLEAN &  
CONVENIENT

ADVANTAGES OF  
**BIOETHANOL  
FIREPLACES**



# BENEFITS



**FLEXIBLE  
INTERIOR DESIGN**

NO FLUE OR CHIMNEY  
REQUIRED – SIMPLE  
INSTALLATION



**INDIVIDUALITY**

SOLUTIONS  
FOR ANY  
INTERIOR



**USER-FRIENDLY  
OPERATION**

FLAME CONTROL  
VIA REMOTE CONTROL  
OR APP



**SAFETY**

STATE-OF-THE-ART  
TECHNOLOGY FOR  
MAXIMUM SAFETY

# LINE THE FLEXIBLE DECO FIRE

Plenty of space  
for customised design

Ebios Fire is ideal for anyone who wants the cosy atmosphere of an open fire without extensive construction work in their house or apartment. No chimney or flue pipe is required to install this Deco Fire.

Whether private home or commercial building; You can install Ebios Fire fireplaces practically anywhere. Thanks to its compact format, the LINE series offers maximum flexibility for fireplace design. No matter the room or preferred use, this series offers the perfect Deco Fire for any need. And with bioethanol as fuel, it's particularly safe and clean.

## INSTALLATION OPTIONS **LINE**

The bioethanol burners of the LINE series feature a long line of flame for an eye-catching interior design feature. The flame height can be adjusted in six levels.

Elegant integration of LINE automatic burners in pieces of furniture is easy, thanks to their compact format. Installation in fixed components such as pedestals, walls or niches is likewise possible.

LINE is available in four different dimensions, permitting flexible adaptation to any interior.

## LINE IN USE



Whether as a highlight at the centre of the room or to accentuate the interior design: Ebios Fire makes it possible to place a Deco Fire anywhere in the home. Even in places that never seemed like an option before!

For instance as a room divider: On request, the decorative burner can be integrated in a partition wall as a tunnel solution. This creates seamless transitions between areas for different functions or – as desired – emphasises zones for rest and relaxation.

A Deco Fire can also be used as a beautiful eye-catcher in a home office: When integrated in a sideboard, the LINE burner's long row of flames creates a pleasantly relaxing atmosphere.

## LINE FACTS

Compact automatic burner with state-of-the-art technology for indoor installation

## BENEFITS

- » 4 standard lengths  
Special dimensions on request
- » Flame height controllable in 6 levels
- » No flue pipe required
- » Automatic tank function
- » Flame protection glass included
- » Decorative logs and decorative stones as accessories

FLAME PROTECTION GLASS

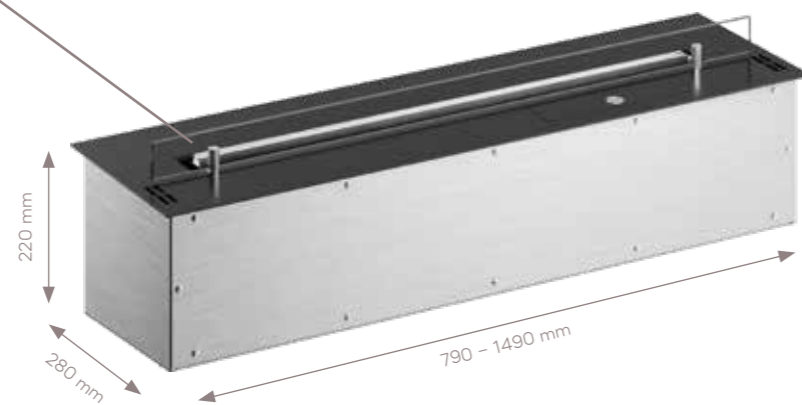

### SMART FIREPLACE ASSISTANCE FUNCTIONS



WiFi

SHS

optional

LINE	800	1000	1200	1500
Length	790 mm	990 mm	1190 mm	1490 mm
Thermal output	max. 4.4 kW	max. 7.0 kW	max. 9.4 kW	max. 13.0 kW
Burner volume	4.3 l	5.5 l	6.8 l	8.6 l
Burning duration	max. 9 h	max. 10 h	max. 11 h	max. 11 h
Room size	min. 44 m <sup>3</sup>	min. 70 m <sup>3</sup>	min. 94 m <sup>3</sup>	min. 130 m <sup>3</sup>
Weight	24.1 kg	27.5 kg	33.0 kg	39.5 kg
Voltage	230 V			



### INSTALLATION OPTIONS



ISLAND

BOARD

THREE-SIDED  
UNIT

TUNNEL

FRAME

CORNER (LEFT)/  
CORNER (RIGHT)

ROOM DIVIDER



# LINE+

## MORE VOLUME, LONG BURNING TIME

### Sometimes you just want more

The LINE+ series with its long row of flames creates an impression of a generously dimensioned fire. The flame height can be adjusted in six levels. LINE+ is available in different dimensions, permitting flexible adaptation to any interior.

Compared with the LINE series, LINE+ models offer more interior space. A larger fuel tank increases the burning time to up to 36 hours.

These fireplaces are ideal for use in private homes and are particularly representative in commercial buildings.



## INSTALLATION OPTIONS **LINE+**

Ebios Fire is not just ideal for private homes: These high-quality Deco Fires also make for the perfect eye-catcher in commercial buildings. Thanks to a wide range of dimensions and customised installation options, there are no limits to your creativity.

Whether in an elegant home or a representative hotel lobby: LINE+ automatic burners can be installed both in pieces of furniture and in fixed components such as pedestals, walls or niches. No connection to a flue pipe is required; a specialised company can install these bioethanol burners practically anywhere.



## LINE+ IN USE



Creative fire design: Placed at the centre of the room, the impressive flames of a Deco Fire can make a truly magical impact. Two LINE+ burners can be combined to create a particularly long row of flame. With an open three-sided unit you can experience the flickering fire from any point in the room.

The body of all Line series models is painted black. This rich dark colour is the perfect stage for the golden glow of the flames. The flame protection glass adds to the overall impression and increases safety.

# LINE+ FACTS

High automatic burner with state-of-the-art bioethanol technology for indoor installation – with greater volume for longer burning time

# BENEFITS

- » 4 standard lengths  
Special dimensions on request
- » Flame height controllable in 6 levels
- » No flue pipe required
- » Automatic tank function
- » Flame protection glass included
- » Decorative logs and decorative stones as accessories

FLAME PROTECTION GLASS

BIOETHANOL TANK

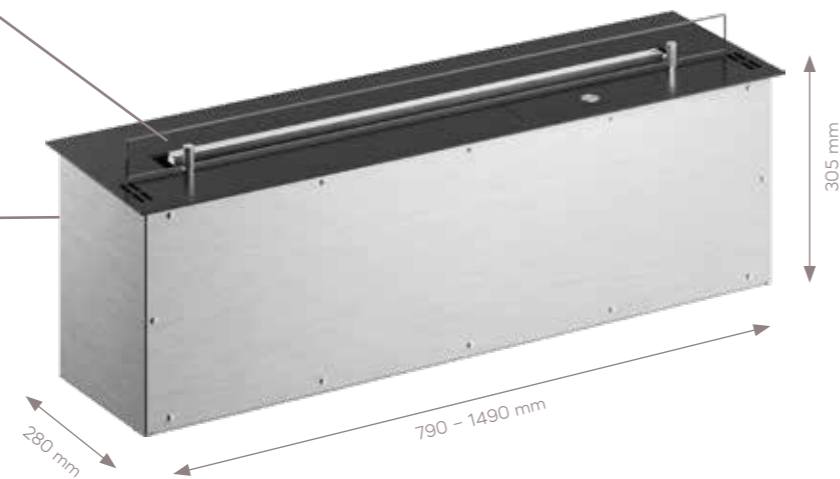

### SMART FIREPLACE ASSISTANCE FUNCTIONS



LINE+	800	1000	1200	1500
Length	790 mm	990 mm	1190 mm	1490 mm
Thermal output	max. 4.4 kW	max. 7.0 kW	max. 9.4 kW	max. 13.0 kW
Burner volume	13.4 l	17.2 l	21.0 l	26.8 l
Burning duration	max. 29 h	max. 31 h	max. 35 h	max. 35 h
Room size	min. 44 m <sup>3</sup>	min. 70 m <sup>3</sup>	min. 94 m <sup>3</sup>	min. 130 m <sup>3</sup>
Weight	24.1 kg	27.5 kg	33.0 kg	39.5 kg
Voltage	230 V			



### INSTALLATION OPTIONS





# BOX THE PERFECT FRAME FOR FLAMES

## Design and safety in harmony

The automatic bioethanol burners LINE and LINE+ of Ebios Fire are either delivered separately or in combination with a pre-configured box. The benefit of these black-coated boxes is that their dark background makes the flickering flames shine even more brightly.

And there are other advantages to the box version as well: Together with the models designed for different interiors the boxes always ensure a perfect transition to adjacent objects such as walls, brick structures or wall niches. Moreover, they guarantee that all safety-relevant distances from flammable objects are maintained.

## DECO FIRE IN PRIVATE HOMES AND COMMERCIAL BUILDINGS



These elegant black boxes make even the most complex design concepts possible. Six different models are available: Three-sided design, tunnel, frame, corner left, corner right and room divider. Thanks to this diversity of options, Ebios Fire offers private building owners, planners and architects the greatest possible flexibility and safety in fireplace design.

The fireplaces can be installed during any phase of the building project, as bioethanol fireplaces require no chimney and no connecting pipes. Even installation after completion of a building project is possible.



# BOX IN USE

BENEFIT  
DESIGN

BENEFIT  
SAFETY

# BENEFITS

All Deco Fires are characterised by their sophisticated design and high-quality workmanship. They feature clear, timeless shapes that blend seamlessly into a modern interior.

Whether private dining room or representative conference room, open showroom or quiet living room: If you want a warm, cosy atmosphere, LINE is an essential design element. Its linear arrangement provides a generous panoramic view of the flickering flames. A Deco Fire can even be integrated in corners. That makes it perfect for creating an elegant fireplace look – all without complicated connections or flues!

Safe and convenient: The operation and height of the flames is controlled electronically and remotely – using the supplied remote control or via WIFI/app. Optional integration of the Line series in Smart Home systems is available.

# BOX FACTS

Pre-fabricated solution consisting of automatic burner plusbox for maintaining all safety-relevant distances

# BENEFITS

- » 6 model variants available
- » Ideal for private homes and commercial buildings
- » Perfect connection to adjacent structures
- » Adherence to safety-relevant distances
- » No flue pipe required

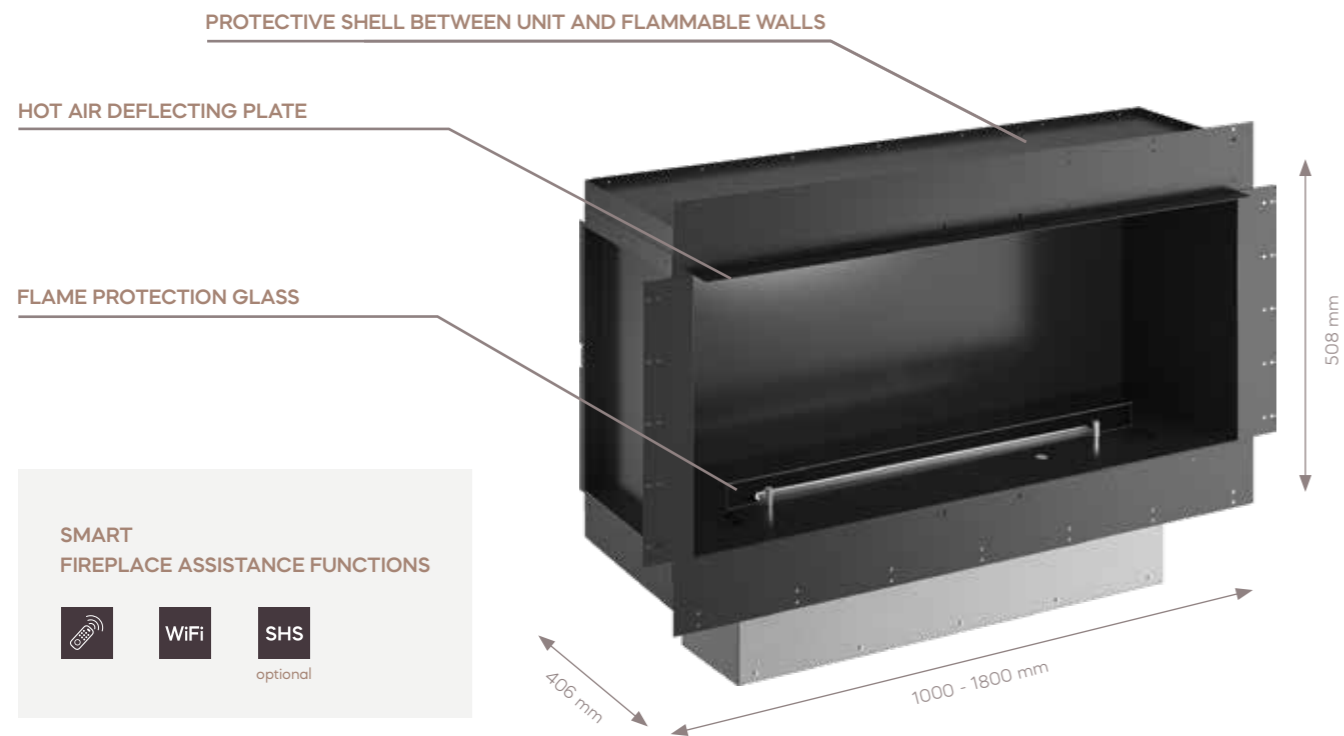

BOX	800	1000	1200	1500
Length	LINE   LINE+ 790 mm	LINE   LINE+ 990 mm	LINE   LINE+ 1190 mm	LINE   LINE+ 1490 mm
	BOX 1000 mm	BOX 1200 mm	BOX 1500 mm	BOX 1800 mm
Thermal output	max. 4.4 kW	max. 7.0 kW	max. 9.4 kW	max. 13.0 kW
Burner volume	LINE   LINE+ 4.3   13.4 l	LINE   LINE+ 5.5   17.2 l	LINE   LINE+ 6.8   21.0 l	LINE   LINE+ 8.6   26.8 l
Burning duration	LINE   LINE+ max. 9 h   max. 29 h	LINE   LINE+ max. 10 h   max. 31 h	LINE   LINE+ max. 11 h   max. 35 h	LINE   LINE+ max. 11 h   max. 35 h
Room size	min. 44 m <sup>3</sup>	min. 70 m <sup>3</sup>	min. 94 m <sup>3</sup>	min. 130 m <sup>3</sup>
Weight	BOX 1V 41.1 kg	BOX 1V 47.1 kg	BOX 1V 56.9 kg	BOX 1V 65.8 kg
	BOX 2L 38.7 kg	BOX 2L 44.7 kg	BOX 2L 54.4 kg	BOX 2L 63.3 kg
	BOX 2R 38.7 kg	BOX 2R 44.7 kg	BOX 2R 54.4 kg	BOX 2R 63.3 kg
	BOX 3RL 36.3 kg	BOX 3RL 44.1 kg	BOX 3RL 51.9 kg	BOX 3RL 60.9 kg
	BOX FD 38.8 kg	BOX FD 41.9 kg	BOX FD 64.4 kg	BOX FD 61.8 kg
	BOX U 36.4 kg	BOX U 41.9 kg	BOX U 51.1 kg	BOX U 59.4 kg
Voltage	230 V			



## MODELS



BOX 1V      BOX 2L      BOX 2R      BOX 3RL      BOX FD      BOX U

## COMFORT AND SAFETY



## PATENTED VAPORIZATION TECHNOLOGY

All Ebios Fire products are part of the most recent generation of bioethanol burners and are equipped with a unique, patented technology:

In principle, the system is based on burning ethanol fumes rather than liquid ethanol. What makes this patent unique is that the unit contains an insulated fuel tank and that only a small volume of bioethanol is heated, converted to vapour and then burned. This controlled and highly efficient combustion system means that there is no direct contact between the fuel and the flame; only the heated fuel vapours ever

reach the fireplace. The refuelling process is monitored by a microprocessor. The aim of this technology is to prevent human error during the refuelling process or while lighting the flame. Operation of the fireplace is constantly monitored by sensors. Moreover, the unit has a child safety guard, i.e. the buttons of the control panel are only activated after three seconds so that the unit cannot be used by anybody not authorised to do so. The patented technology of the Ebios Fire Deco Fire ensures maximum safety and cleanliness and creates an even flame pattern at all times.

Ebios Fire is based on a unique, automatic and therefore particularly safe bioethanol technology:

The core of every bioethanol burner is its automatic refuelling system: The bioethanol fuel is located in an insulated supply tank in the system interior. The actual combustion chamber is separate from the tank. Liquid bioethanol is transported from the tank to a vaporiser. A special, microprocessor-controlled pump ensures that only the required volume of bioethanol enters the combustion chamber.

Refuelling is clean and therefore safer. In addition to providing convenient operation, this innovative design ensures that there is no contact of the liquid fuel and the flames.

The fuel supply and flames can be switched on and switched off completely at the

push of a button. Ebios Fire offers a remote control for controlling the flames; alternatively the system can be controlled via WIFI/app using mobile devices. Optional integration into existing Smarthome systems is possible. Ebios Fire provides a maximum of safety at all times.

And to top it all off: Thanks to Deco Fire's practically complete combustion process, there is no smoke, soot or unpleasant odour.

### Bioethanol fuel



The fuel for the Deco Fire of Ebios Fire – bioethanol – consists of plant-based raw materials such as grain, corn or potatoes. This means it is a renewable resource based fuel. It is regarded as climate-neutral because burning it only releases the amount of CO<sub>2</sub> that the plants previously removed from the atmosphere. This makes bioethanol a sustainable alternative to fossil fuels.

# EBIOS FIRE

by SPARTHERM®

## DEALER



-  [www.facebook.com/Spartherm](https://www.facebook.com/Spartherm)
-  [www.instagram.com/spartherm](https://www.instagram.com/spartherm)
-  [www.youtube.com/sparthermgermany](https://www.youtube.com/sparthermgermany)

[www.ebios-fire.com](https://www.ebios-fire.com)

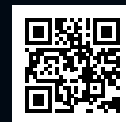

Ebios Fire – a trademark of Spartherm Feuerungstechnik GmbH



[www.drufire.com](https://www.drufire.com)

**Drugasar Ltd.**  
Deans Road | Swinton  
Manchester | M27 0JH  
United Kingdom  
T. +44 (0)161 - 793 8700